

**ECG55-6 | Electrical drivetrain | Duplex, clear view, standard - LH 4500**

	<b>ECG55-6</b>
<b>Lifting data</b>	
Lifting capacity, rated (kg)	5500
Lifting speed L4, unloaded – at 70% of rated load (m/s)	0,40 - 0,35
Lowering speed L4, unloaded – at rated load (m/s)	0,45 - 0,50
<b>Driving data</b>	
Travelling speed forward, unloaded – at rated load (km/h)	18 - 16
Travelling speed backward, unloaded – at rated load (km/h)	18 - 16
Gradeability max., unloaded – at rated load (%)	53 - 30
Gradeability at 2 km/h, unloaded – at rated load (%)	40 - 23
Drawbar pull, max. (kN)	40
<b>Weight of truck</b>	
Weight, with battery - without battery (kg)	-
Axle load front, unloaded – at rated load (kg)	-
Axle load rear, unloaded – at rated load (kg)	-
<b>Drivetrain</b>	
Drive axle – type	Differential and hub reduction
Drive motor, hourly capacity (kW)	2 × 17,6 kW - S2 60 min
Speed control, principle – number of steps	High frequency MOSFET, AC - Stepless
Pump motor hydraulics, intermittent capacity – duty factor (kW)	1 × 42 kW - S3 15%
Pump motor brakes, intermittent capacity – duty factor (kW)	1 × 2,2 kW - S1 100%
Pump control, principle – number of steps	High frequency MOSFET, AC - Stepless
<b>Battery</b>	
Dimensions, W × H × L (mm)	1295 × 780 × 845
Capacity at 5h discharging – voltage (Ah – V)	940A - 80V (75 kWh)
Max. charging current (A – V)	175 - 80
Weight, with battery - without battery (kg)	2300
<b>Wheels</b>	
Type	Pneumatic / Diagonal
Dimension, front – rear (inch)	315/70-15 – 225/75-15
Number of wheels, front – rear (*driven)	2* - 2
<b>Miscellaneous</b>	
Steering system, type – maneuvering	Hydraulic servo - Steering wheel
Service brake system, type – affected wheels	Oil cooled disc brakes – Drive wheel
Parking brake system, type – affected wheels	Dry, spring activated disc brakes - Drive wheel
Max. hydraulic pressure (MPa)	14,5
Noise level EN12053 with ECO modes - equivalent inside cabin LpAZ (dB(A))	-
Noise level EN12053 with ECO-modes - equivalent outside cabin LwAZ (dB(A))	-
Hydraulic oil volume (l)	125

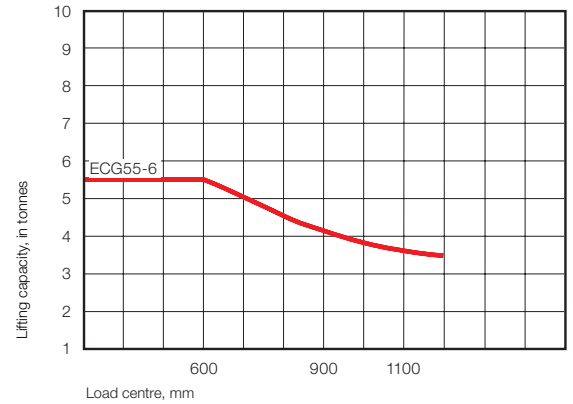
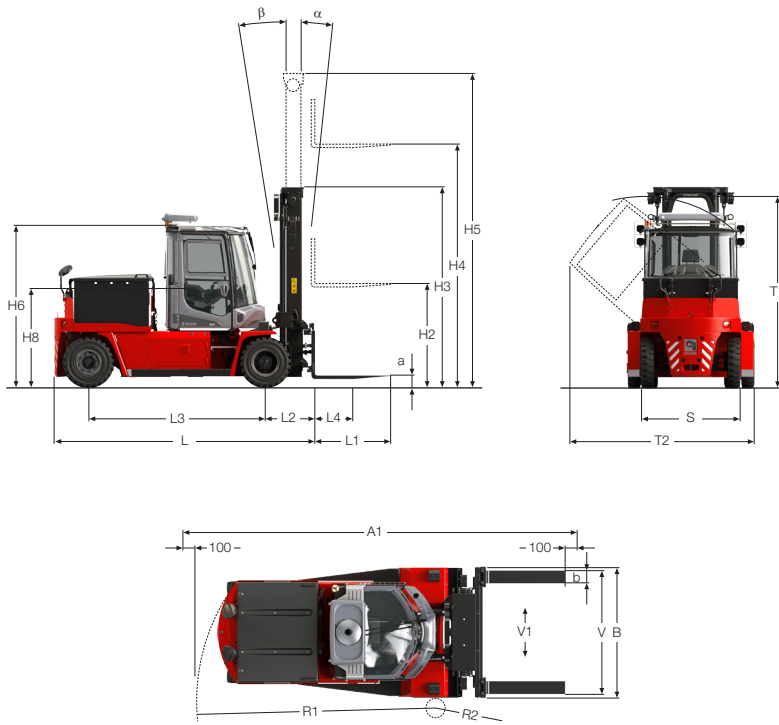

## Dimensions

Length of truck (mm)	L	3410
Width of truck (mm)	B	1550
Height of basic machine (mm)	H6	2590
Height of seat (mm)	H8	1440
Wheelbase (mm)	L3	2100
Load centre (mm)	L4	600
Track (c-c), front – rear (mm)	S	1240 - 1266
Turning radius, outer – inner (mm)	R1-R2	3000 - 115
Ground clearance, min. (mm)		160
Max. height when tilting cab (mm)	T1	3020
Max. width when tilting cab (mm)	T2	3000
Lifting height (mm)	H4	4500
Mast height, min. (mm)	H3	3120
Mast height, max. (mm)	H5	5500
Tilting of mast, forward - backward (°)	$\alpha$ - $\beta$	5 - 10
Fork width (mm)	b	150
Fork thickness (mm)	a	60
Length of forkarm (mm)	l	1200
Width across fork arms, max. - min. (mm)	V	-
Sideshift $\pm$ at width of across fork arms (mm)	V1-V	-

The design and materials specification are subject to alternation without prior notice.  
Tolerances according to K-standard 95430.0008/0009

Kalmar offers the widest range of cargo handling solutions and services to ports, terminals, distribution centres and to heavy industry. Kalmar is the industry forerunner in terminal automation and in energy efficient container handling, with one in four container movements around the globe being handled by a Kalmar solution. Through its extensive product portfolio, global service network and ability to enable a seamless integration of different terminal processes, Kalmar improves the efficiency of every move. [www.kalmarglobal.com](http://www.kalmarglobal.com)

Kalmar is part of Cargotec. Cargotec's sales in 2018 totalled approximately EUR 3.3 billion and it employs around 12.000 people. [www.cargotec.com](http://www.cargotec.com)



Cargotec Sweden AB  
Movägen 1  
SE-341 32, Ljungby, Sweden  
tel. +46 372 260 00  
[www.kalmarglobal.com](http://www.kalmarglobal.com)